

# Interacting branching processes and linear file-sharing networks

**Florian Simatos**

CWI

**Edinburgh, June 7, 2010**

Joint work with **L. Leskelä** (Helsinki) and **P. Robert** (INRIA)

# Peer-to-peer networks

## Peer-to-peer

- ▶ Peer = client + server

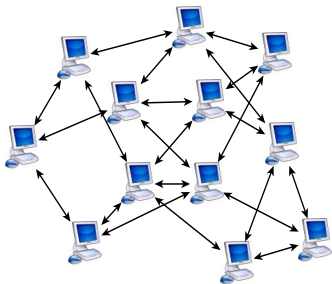

## Client-server

- ▶ Fixed capacity

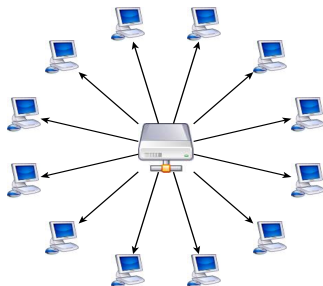

Infrastructure evolves in time

# Peer-to-peer networks

## Files cut into chunks

- ▶ Speeds up dissemination
- ▶ Algorithmic issues: which chunks to exchange?

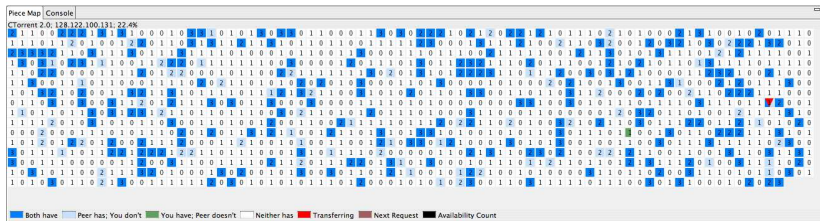

# Peer-to-peer networks

## Large systems

- ▶ **Thousands of chunks**
- ▶ **Millions of users**

## Originally for file-sharing

- ▶ **Streaming, telephony, ...**

**Model**

**Results**

# Context

Model inspired by peer-to-peer systems

Two main ingredients:

- ▶ Peer = client + server (scalable capacity)
- ▶ Large file cut into  $n \geq 1$  chunks

Stability of such systems: few results

In this talk,  $n = 2$

- ▶ Simplest interesting case
- ▶ Same ideas work for general  $n \geq 1$

# Two assumptions

See Parvez et al. (2008)

1. Peers collect two pieces, **1** and **2**, in order
2. Download from peers with **one more piece**

# Model

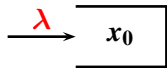

Arrival rate  $\lambda$

# Model

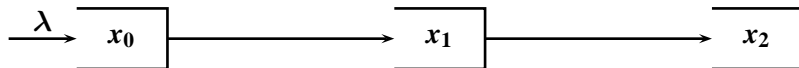

Arrival rate  $\lambda$

Download pieces sequentially

- ▶ Linear structure

# Model

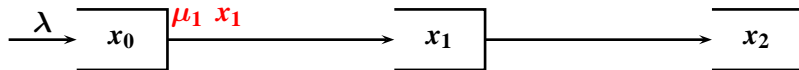

Arrival rate  $\lambda$

Download pieces sequentially

- ▶ Linear structure

Download from peers with one more piece

- ▶ Peer-to-peer dynamics:  $x_1$  servers

# Model

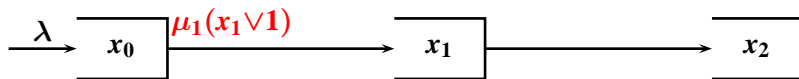

Arrival rate  $\lambda$

Download pieces sequentially

- ▶ Linear structure

Download from peers with one more piece

- ▶ Peer-to-peer dynamics:  $x_1$  servers
- ▶  $x_1 \vee 1 = \max(x_1, 1)$ : 0 not absorbing ( $x_1 + 1, \dots$ )

# Model

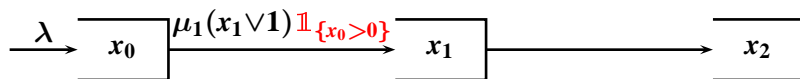

Arrival rate  $\lambda$

Download pieces sequentially

- ▶ Linear structure

Download from peers with one more piece

- ▶ Peer-to-peer dynamics:  $x_1$  servers
- ▶  $x_1 \vee 1 = \max(x_1, 1)$ : 0 not absorbing ( $x_1 + 1, \dots$ )
- ▶  $\mathbb{1}_{\{x_0 > 0\}}$ : need  $x_0 \geq 0$

# Model

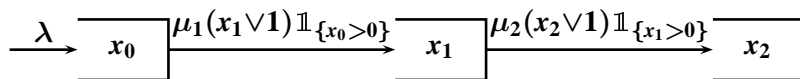

Arrival rate  $\lambda$

Download pieces sequentially

- ▶ Linear structure

Download from peers with one more piece

- ▶ Peer-to-peer dynamics:  $x_1$  servers
- ▶  $x_1 \vee 1 = \max(x_1, 1)$ : 0 not absorbing ( $x_1 + 1, \dots$ )
- ▶  $\mathbb{1}_{\{x_0 > 0\}}$ : need  $x_0 \geq 0$

# Model

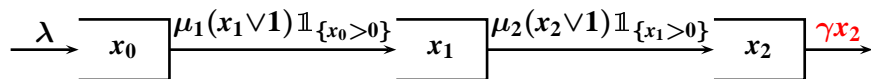

Arrival rate  $\lambda$

Download pieces sequentially

- ▶ Linear structure

Download from peers with one more piece

- ▶ Peer-to-peer dynamics:  $x_1$  servers
- ▶  $x_1 \vee 1 = \max(x_1, 1)$ : 0 not absorbing ( $x_1 + 1, \dots$ )
- ▶  $\mathbb{1}_{\{x_0 > 0\}}$ : need  $x_0 \geq 0$

Then leave

# Model

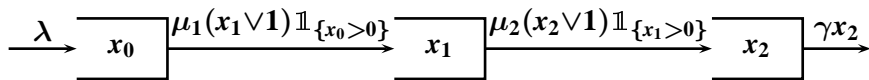

$(X(t)) = (X_0(t), X_1(t), X_2(t))$  Markov chain:

► Transition rates:

$$\begin{cases} Q(x, x + e_0) & = \lambda & \text{(arrival)} \\ Q(x, x - e_i + e_{i+1}) & = \mu_{i+1}(x_{i+1} \vee 1) \mathbb{1}_{\{x_i > 0\}} & \text{(transition)} \\ Q(x, x - e_2) & = \gamma x_2 & \text{(departure)} \end{cases}$$

Stability condition on  $\lambda, \mu_1, \mu_2, \gamma$ ?

► In this talk,  $\boxed{\mu_2 - \gamma > \mu_1} \Rightarrow \mu_2 > \gamma$

# Fluid equations

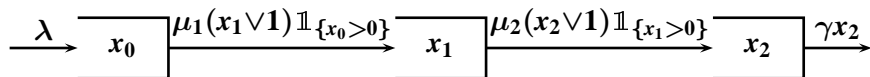

Corresponding fluid equations:

$$\begin{cases} \dot{x}_0(t) = \lambda - \mu_1 x_1(t) \\ \dot{x}_1(t) = \mu_1 x_1(t) - \mu_2 x_2(t) \\ \dot{x}_2(t) = \mu_2 x_2(t) - \gamma x_2(t) \end{cases}$$

Link to stability?

Boundary conditions?

- ▶  $x \vee 1$  in the fluid scale?

# Results

# Drift arguments

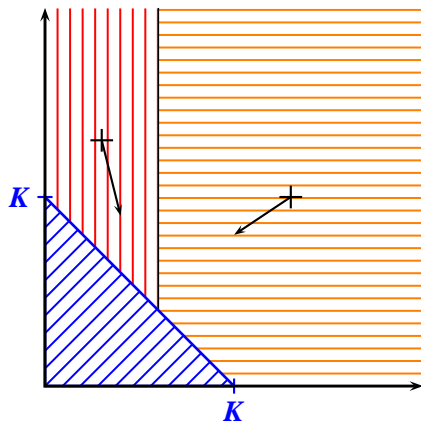

**Foster's criterion:**

For some  $t, K, \eta > 0$ ,

$$\mathbb{E}_x(\|X(t)\| - \|x\|) \leq -\eta$$

for all  $\|x\| \geq K$ .

## Partition of the state space $\mathbb{N}^3$

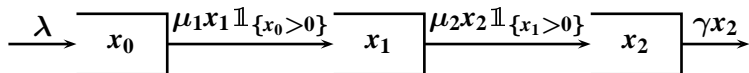

Start from a large initial state  $X(0) = x = (x_0, x_1, x_2)$  :

- ▶  $x_2 \gg 1$
- ▶  $x_1 \gg 1$  and  $x_2$  small
- ▶  $x_0 \gg 1$  and  $x_1, x_2$  small

## Partition of the state space $\mathbb{N}^3$

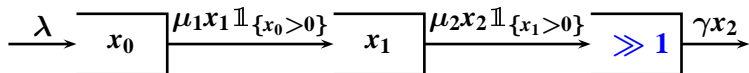

Start from a large initial state  $X(0) = x = (x_0, x_1, x_2)$  :

- ▶  $x_2 \gg 1$
- ▶  $x_1 \gg 1$  and  $x_2$  small
- ▶  $x_0 \gg 1$  and  $x_1, x_2$  small

## Partition of the state space $\mathbb{N}^3$

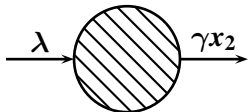

Start from a large initial state  $X(0) = x = (x_0, x_1, x_2)$  :

- ▶  $x_2 \gg 1$  :  $\lambda - \gamma x_2 < 0$
- ▶  $x_1 \gg 1$  and  $x_2$  small
- ▶  $x_0 \gg 1$  and  $x_1, x_2$  small

## Partition of the state space $\mathbb{N}^3$

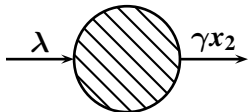

Start from a large initial state  $X(0) = x = (x_0, x_1, x_2)$  :

- ▶  $x_2 \gg 1$ : ok
- ▶  $x_1 \gg 1$  and  $x_2$  small
- ▶  $x_0 \gg 1$  and  $x_1, x_2$  small

## Partition of the state space $\mathbb{N}^3$

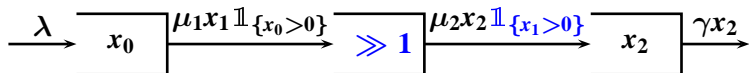

Start from a large initial state  $X(0) = x = (x_0, x_1, x_2)$  :

- ▶  $x_2 \gg 1$ : ok
- ▶  $x_1 \gg 1$  and  $x_2$  small
- ▶  $x_0 \gg 1$  and  $x_1, x_2$  small

## Partition of the state space $\mathbb{N}^3$

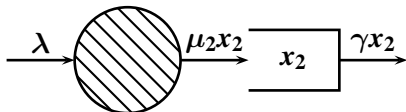

Start from a large initial state  $X(0) = x = (x_0, x_1, x_2)$  :

▶  $x_2 \gg 1$ : ok

▶  $x_1 \gg 1$  and  $x_2$  small

▶  $x_0 \gg 1$  and  $x_1, x_2$  small

$$\dot{x}_2 = (\mu_2 - \gamma)x_2$$

- ▶  $\mu_2 > \gamma$ : exponential growth
- ▶ Coupling with a transient birth-death chain

## Partition of the state space $\mathbb{N}^3$

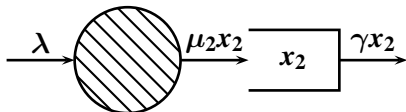

Start from a large initial state  $X(0) = x = (x_0, x_1, x_2)$  :

- ▶  $x_2 \gg 1$ : ok
- ▶  $x_1 \gg 1$  and  $x_2$  small: ok
- ▶  $x_0 \gg 1$  and  $x_1, x_2$  small

$$\dot{x}_2 = (\mu_2 - \gamma)x_2$$

- ▶  $\mu_2 > \gamma$ : exponential growth
- ▶ Coupling with a transient birth-death chain

## Sub-system ( $Z(t)$ ) — I

Remains:  $x_0 \gg 1$  and  $x_1, x_2$  small

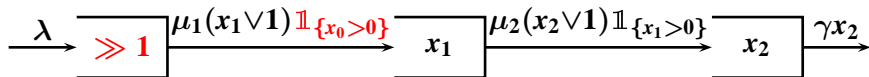

## Sub-system ( $Z(t)$ ) — I

Remains:  $x_0 \gg 1$  and  $x_1, x_2$  small

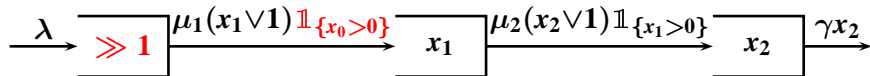

$x_0 \gg 1 \Rightarrow$  for a long time,  $(X_1(t), X_2(t)) = (Z_1(t), Z_2(t))$

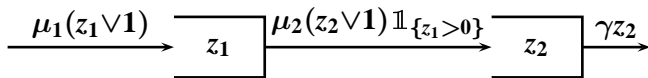

Output driven by  $Z_2(t)$ :

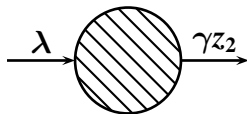

## Sub-system ( $Z(t)$ ) — II

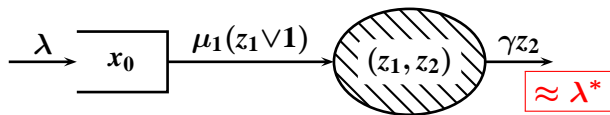

### Aim of the analysis:

- ▶ Show that  $(Z(t), t \geq 0)$  is stable:

$$\lambda^* = \gamma \mathbb{E}(Z_2(\infty))$$

- ▶ Stability condition:  $\lambda < \lambda^*$

# Study of the sub-system

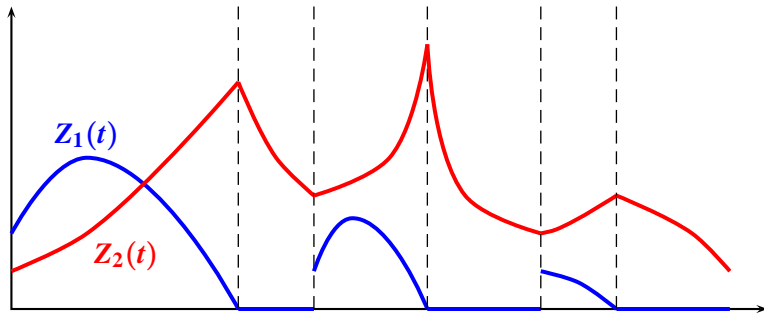
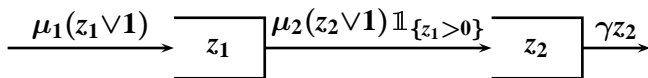

# Study of the sub-system

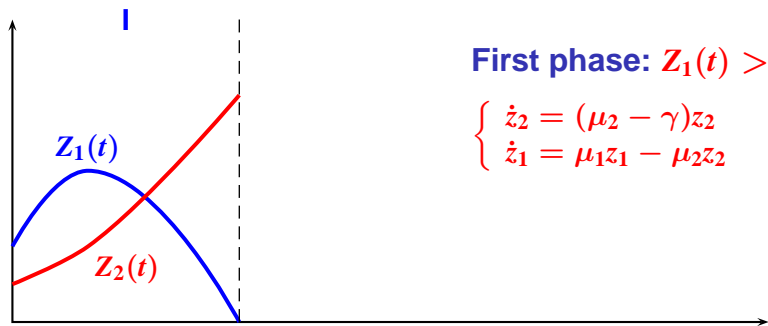
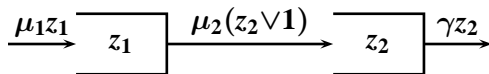

# Study of the sub-system

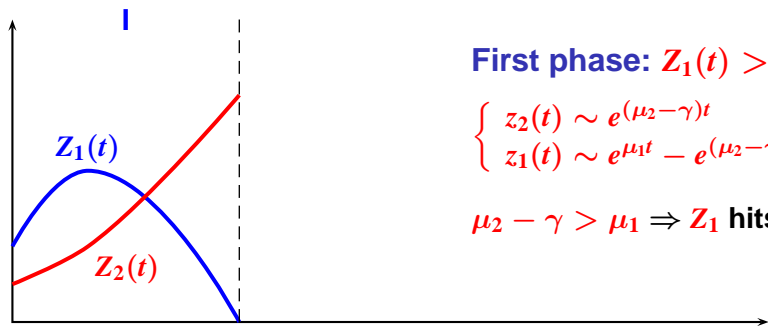
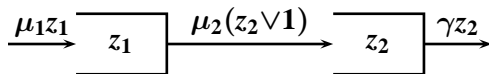

# Study of the sub-system

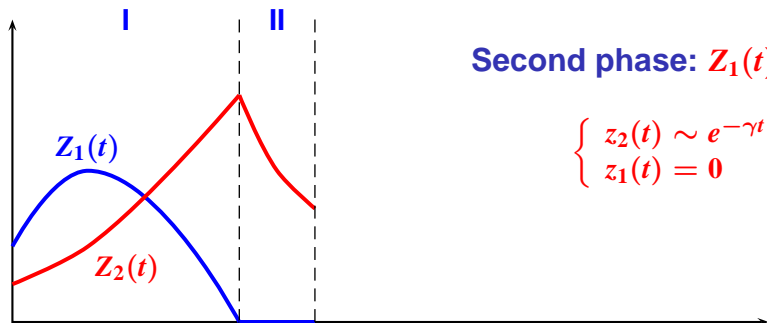
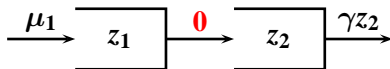

**Second phase:  $z_1(t) = 0$**

$$\begin{cases} z_2(t) \sim e^{-\gamma t} \\ z_1(t) = 0 \end{cases}$$

# Study of the sub-system

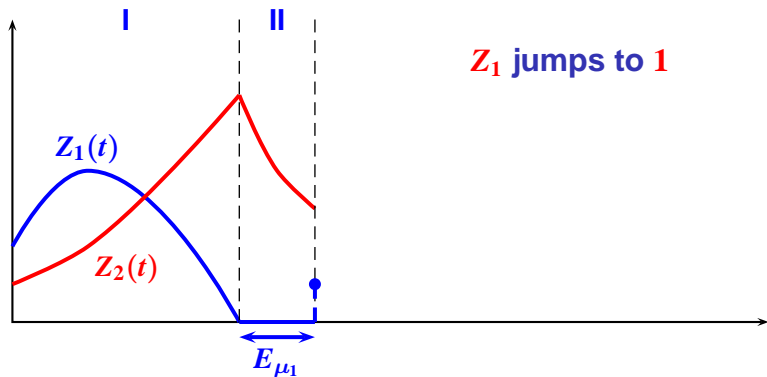
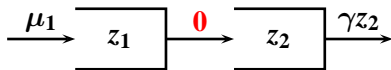

# Study of the sub-system

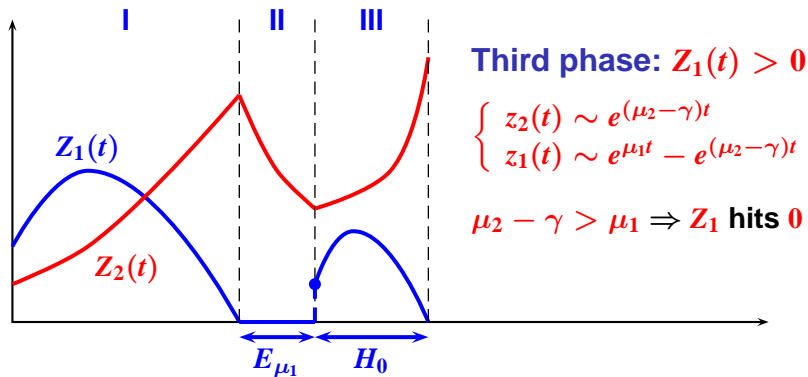
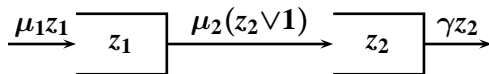

# Study of the sub-system

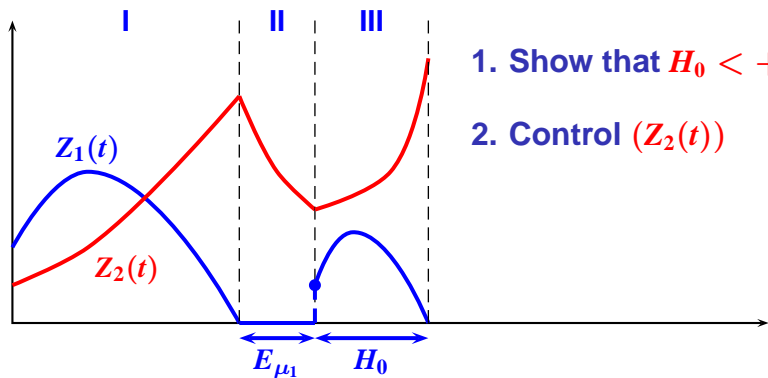
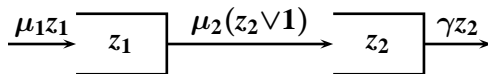

1. Show that  $H_0 < +\infty$

2. Control ( $Z_2(t)$ )

# Tree representation of the sub-system — I

## Yule process

- ▶ Exponential lifetime,  $\mu$
- ▶ Splits into 2 particles

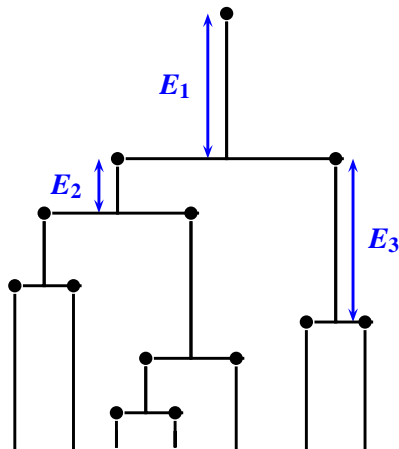
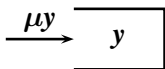

## Tree representation of the sub-system — II

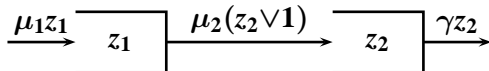

$Z_1(t) > 0$ : competition

- ▶ Births ( $\sigma_n$ ) in  $Z_2$
- ▶ Births in  $Z_1$

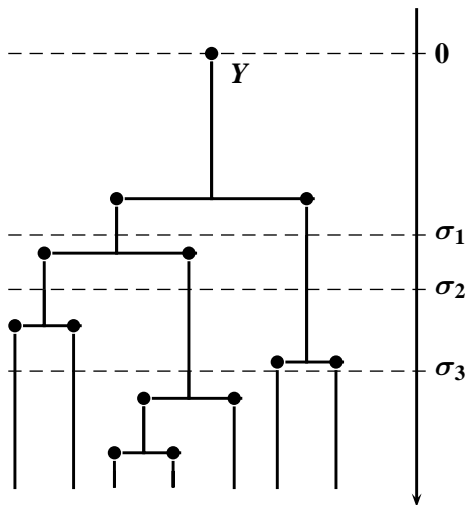

## Tree representation of the sub-system — II

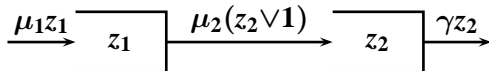

$Z_1(t) > 0$ : competition

- ▶ Births ( $\sigma_n$ ) in  $Z_2$
- ▶ Births in  $Z_1$

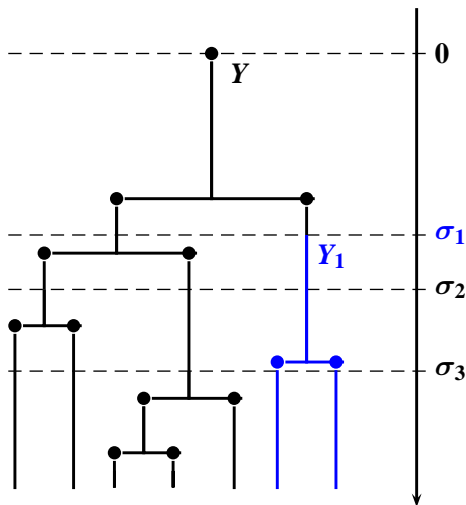

## Tree representation of the sub-system — II

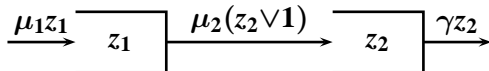

$Z_1(t) > 0$ : competition

- ▶ Births ( $\sigma_n$ ) in  $Z_2$
- ▶ Births in  $Z_1$

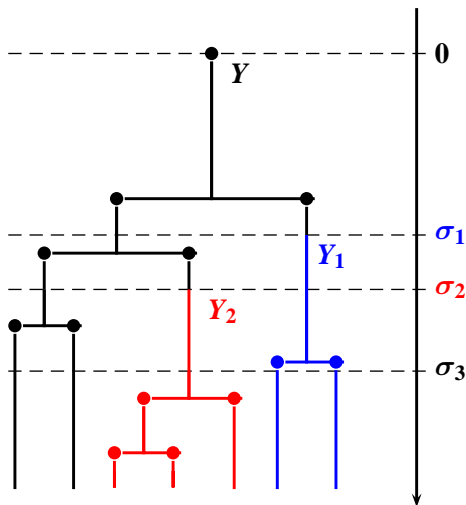

# Tree representation of the sub-system — II

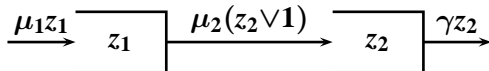

$Z_1(t) > 0$ : competition

- ▶ Births ( $\sigma_n$ ) in  $Z_2$
- ▶ Births in  $Z_1$

Yule process  $Y$

$$Z_1 = Y - Y_1 - Y_2 - Y_3 - \dots$$

Proposition

$Z_1$  hits 0 in finite time, a.s.

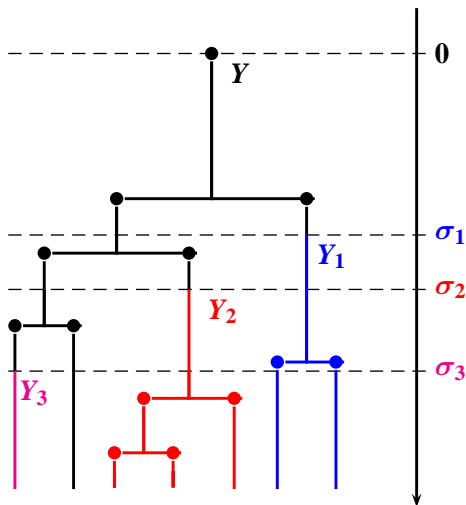

## Stability of the sub-system

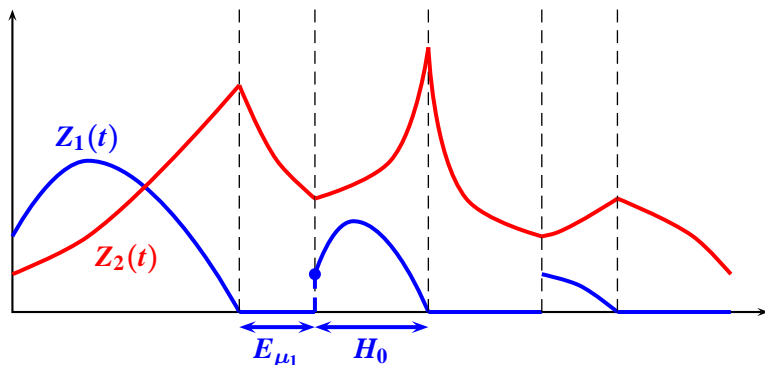
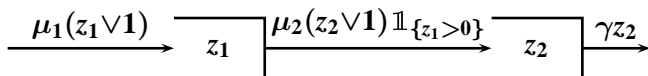

$H_0 < +\infty$  and moreover  $\mathbb{E}(H_0) < +\infty$

# Stability of the sub-system

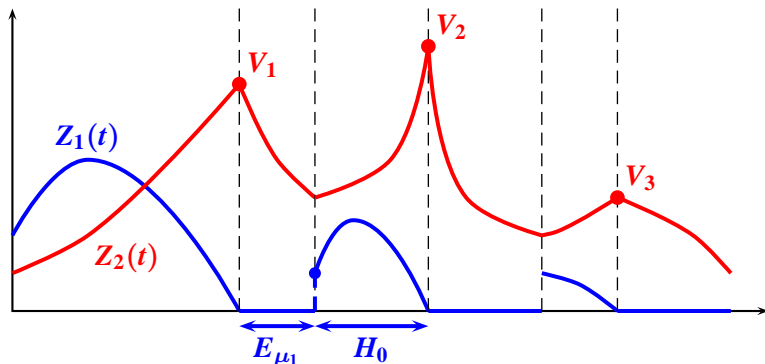
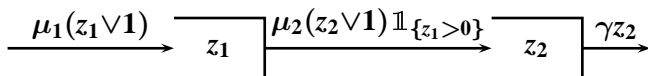

$H_0 < +\infty$  and moreover  $\mathbb{E}(H_0) < +\infty$

Show that  $(V_n)$  is ergodic

# Stability of the sub-system

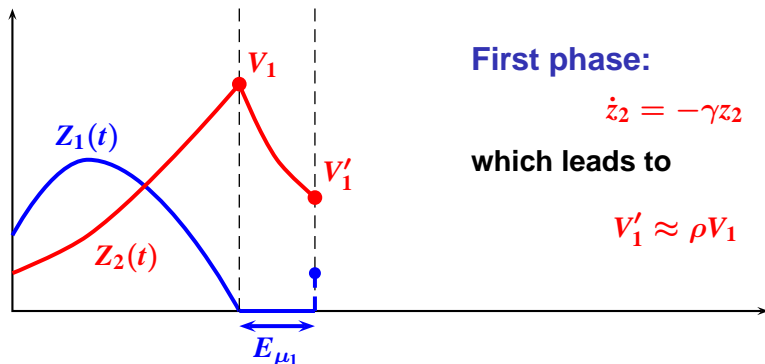
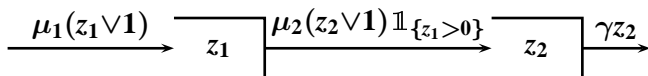

**First phase:**

$$\dot{z}_2 = -\gamma z_2$$

which leads to

$$V'_1 \approx \rho V_1$$

$H_0 < +\infty$  and moreover  $\mathbb{E}(H_0) < +\infty$

Show that  $(V_n)$  is ergodic

# Stability of the sub-system

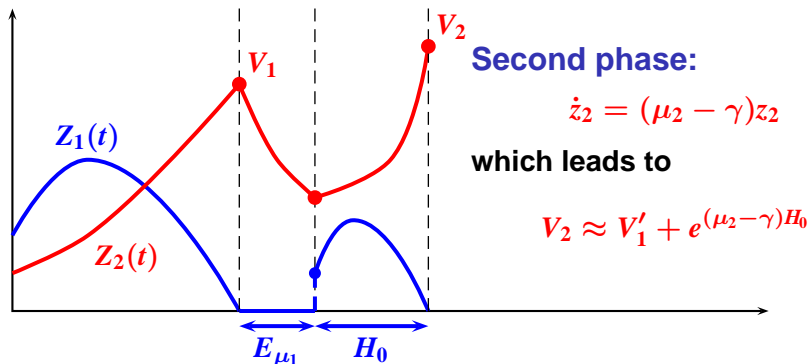
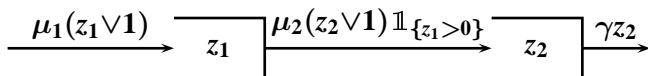

**Second phase:**

$$\dot{z}_2 = (\mu_2 - \gamma)z_2$$

which leads to

$$V_2 \approx V_1' + e^{(\mu_2 - \gamma)H_0}$$

$H_0 < +\infty$  and moreover  $\mathbb{E}(H_0) < +\infty$

Show that  $(V_n)$  is ergodic

# Stability of the sub-system

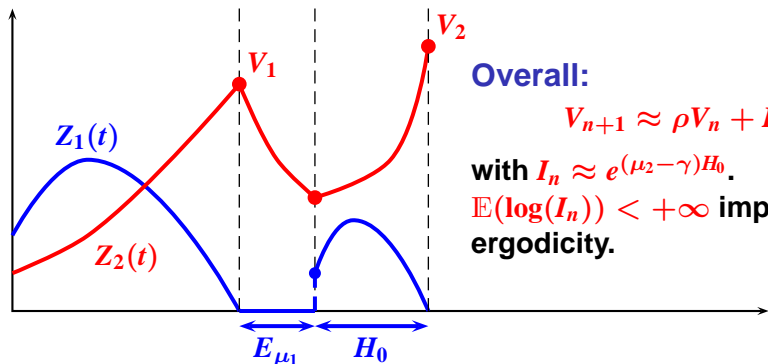
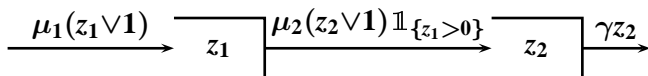

**Overall:**

$$V_{n+1} \approx \rho V_n + I_n$$

with  $I_n \approx e^{(\mu_2 - \gamma)H_0}$ .

$\mathbb{E}(\log(I_n)) < +\infty$  implies ergodicity.

$H_0 < +\infty$  and moreover  $\mathbb{E}(H_0) < +\infty$

Show that  $(V_n)$  is ergodic

# Summary

$x_2 \gg 1$  or  $x_2$  small and  $x_1 \gg 1$ : ok

$x_0 \gg 1$  and  $x_1, x_2$  small: output driven by  $(Z(t))$

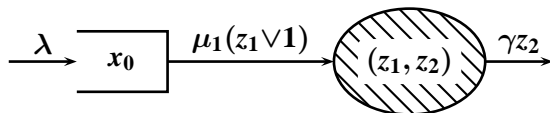

Under  $\mu_2 - \gamma > \mu_1$ ,  $(Z(t), t \geq 0)$  is stable

- ▶ Stability condition:  $\lambda < \lambda^* = \gamma \mathbb{E}(Z_2(\infty))$
- ▶  $\mathbb{E}(Z_2(\infty)) < +\infty$  ??

# Conclusion

## Stability difficult to analyze

- ▶ Coupling with branching processes

## Generalization to $n$ pieces:

If

$$\mu_1 > \mu_2 > \dots > \mu_n - \gamma > 0$$

then infinite stability region.

## Limitations of the model

- ▶ Rarest-first?
- ▶ Locality